

# FRONT BOTTOM CUSHION - MOUNTING HIP RESTRAINTS **CC PRECEDENT**

## STEP 1 - Drill Holes In Hip Restraints

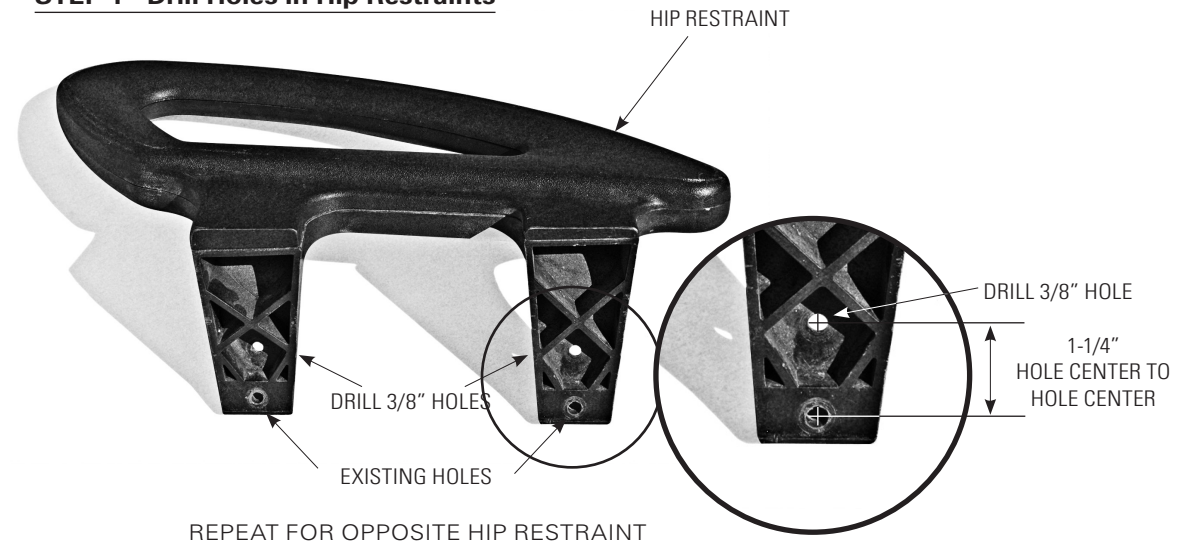

## STEP 2 - Mount Hip Restraints

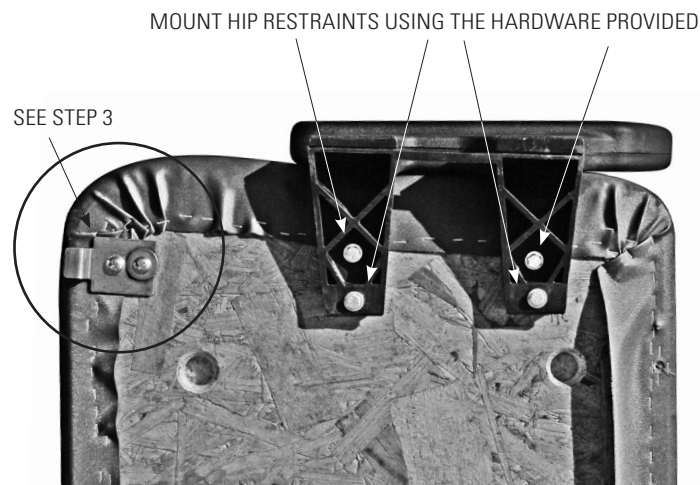

## STEP 3 - Mount Seat Brackets

MOUNT THE FACTORY SEAT BRACKETS USING THE HARDWARE PROVIDED

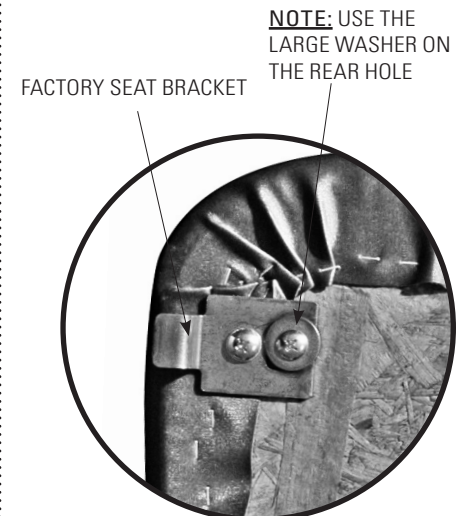

PROPRIETARY & CONFIDENTIAL  
THE INFORMATION CONTAINED IN THIS DOCUMENT IS THE SOLE PROPERTY OF CUSTOM GOLF CAR SUPPLY. ANY REPRODUCTION IN PART OR AS A WHOLE, WITHOUT THE WRITTEN PERMISSION OF CUSTOM GOLF CAR SUPPLY IS PROHIBITED.

