

LIMO TRACK TOP™

6-PASSENGER TOP KITS



IMPORTANT: Do not fully tighten hardware until instructed.
Read through all instructions before beginning installation.

REAR FRAME INSTALLATION

NOTE: Kits include Rear Frames and Front Frame Brackets where applicable.

TABLE OF CONTENTS:

- Step 1** - Install Front Frame Brackets
- Step 2** - Install Rear Frames
- Step 3** - Install Top

PREPARE CAR FOR INSTALLATION:

Remove the following:

- Factory Top • Top Supports/Drain Tubes
- Bench Back Cushion • Bag Rack Assembly

NOTE: Save original Hardware for later use.

STEP 1

INSTALL FRONT FRAME BRACKETS

(SEE INSTRUCTIONS INCLUDED WITH FRONT FRAME BRACKET KIT.)

STEP 2

INSTALL REAR FRAMES

Rear Frames

See Seat Plate Kit Instructions for mounting to Seat Back Supports.
Mount the Rear Frames, to the Seat Back Supports, with the top bent legs facing to the rear of the car.

NOTE: Fully tighten Bolts.

Shown on Club Car Precedent seat back supports

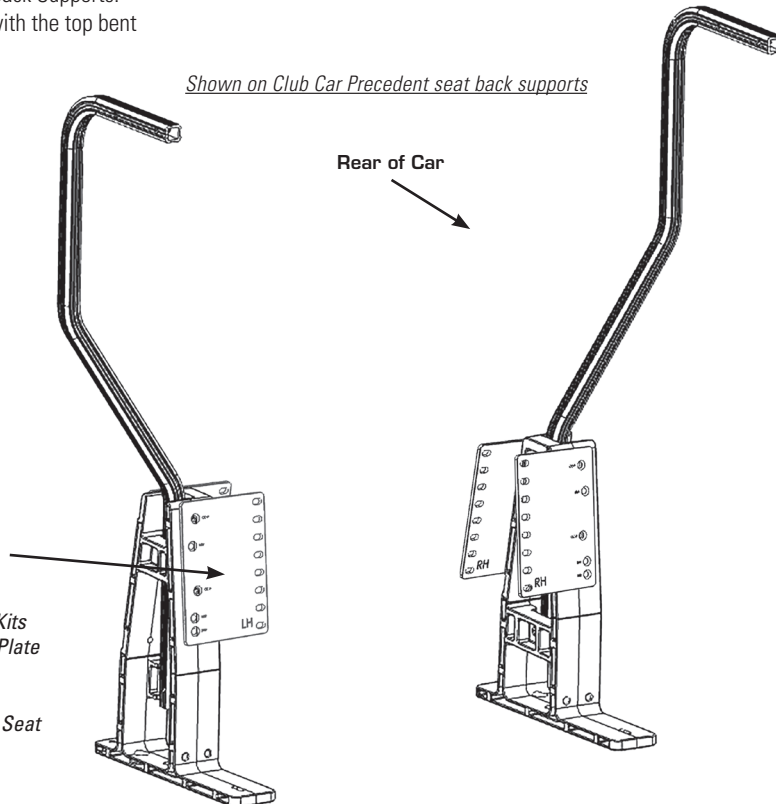

Universal Seat Plate
(Provided with DoubleTake Rear Seat Kits)

If you are using a DoubleTake Rear Seat Kit, it's easier to install the Universal Seat Plate Kits before installing the Rear Frames (See Seat Plate Kit Instructions provided with Rear Seat Kit).

If you are NOT installing a DoubleTake Rear Seat Kit, disregard the Seat Plates.

STEP 3

INSTALL TOP

Mounting Front Brackets

Rest the Top on Front and Rear Frames, attach Front Frames with provided hardware as shown.

NOTE: Do not fully tighten Bolts.

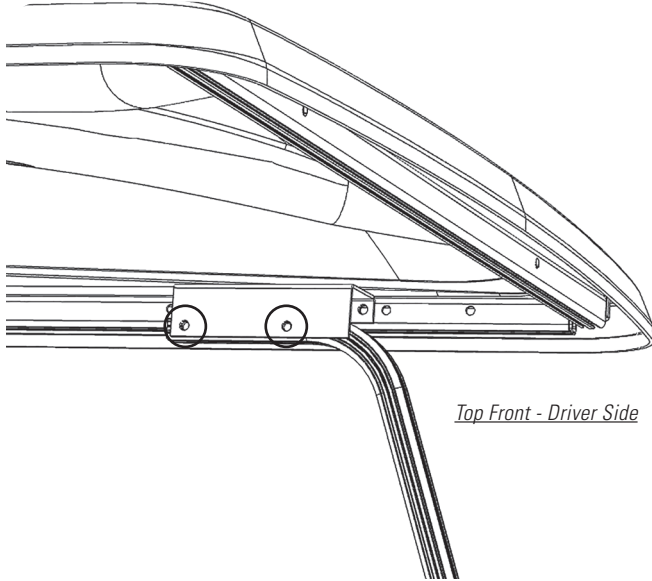

Mounting Single Front Bracket

**Spacers shown below mount between the Bracket and inside of the Top Frame.*

Rest the Top on Front and Rear Frames, attach Front Frames to Brackets with provided hardware.

NOTE: Do not fully tighten Hardware.

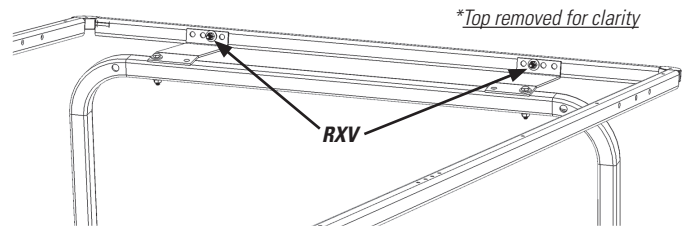
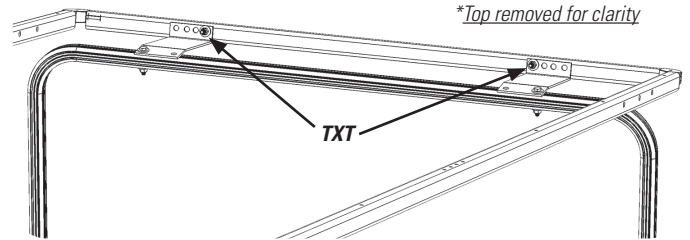

Mounting Rear Frames

**IMPORTANT: Place Scrap Material between Top Frame and Top before drilling (See below).*

Clamp Rear Frame to the Top Frame. Double check Rear Frame positioning (plumb/level) and chase drill holes through Rear Frame and Top Frame.

NOTE: Fully tighten all Hardware.

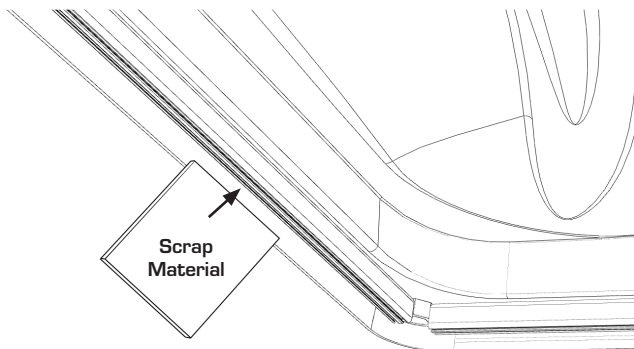

(Insert between Top and Top Frame when drilling)

