

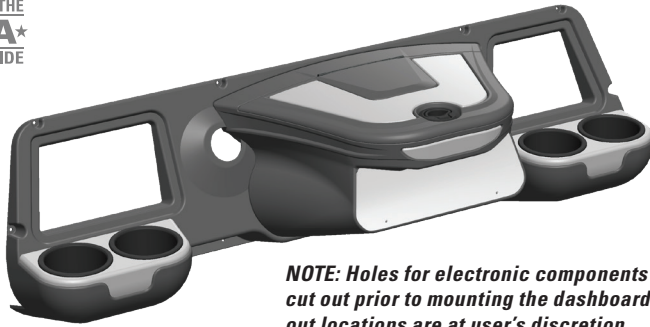

MADE IN THE
★USA★
WITH PRIDE



NOTE: Holes for electronic components should be cut out prior to mounting the dashboard. These cut out locations are at user's discretion.

SENTRY
LOCKING STORAGE DASH

**CLUB CAR® DS® /
DOUBLETAKE® SPARTAN™**

TABLE OF CONTENTS:

- Section 1** - Car Preparation
- Section 2** - Sentry Dash Installation
- Section 3** - Trim Kit Installation

IMPORTANT: Read through all instructions before beginning installation.

SECTION 1

CAR PREPARATION

1:1 REMOVE KEY SWITCH COVER PLATE

Remove the factory key switch cover plate and detach all electrical components.

1:2 REMOVE ELECTRICAL COMPONENTS

Remove all electrical components from the factory dash. Set aside to be installed in Sentry Dash.

1:3 REMOVE CUP HOLDERS

If present, remove any factory or aftermarket cup holders from the front of the dash area.

1:4 REMOVE STEERING WHEEL

Remove the center cap/scorecard holder from center of steering wheel. Remove lagre nut and pull steering wheel off of steering column shaft.

Club Car DS / DoubleTake Spartan

Car with factory components removed and ready for Sentry Dash installation

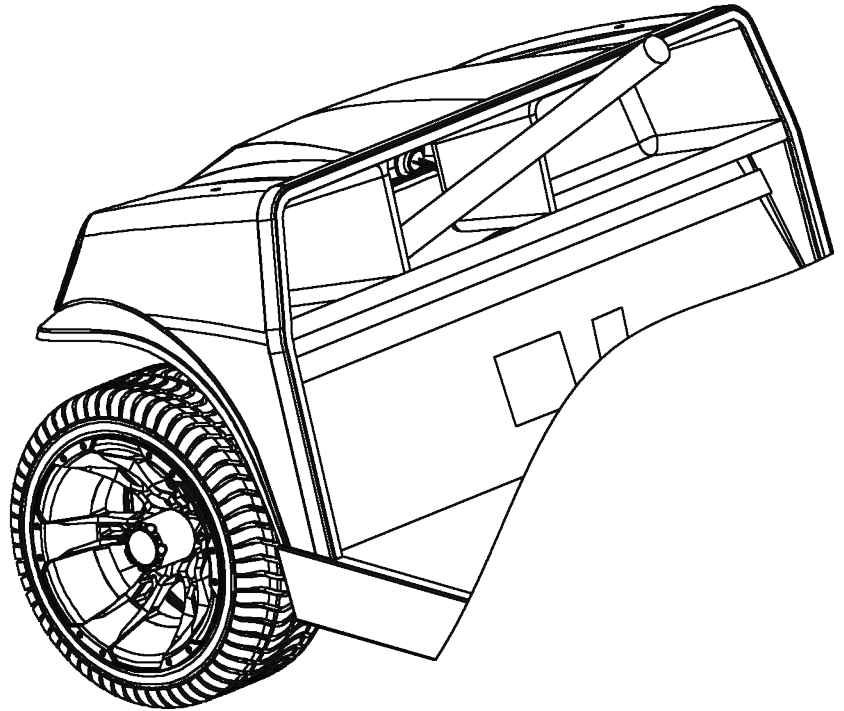

SECTION 2

SENTRY DASH INSTALLATION

2:1 POSITION SENTRY DASH

Slide the Sentry Dash over the steering column (A), while pulling any wiring for electrical components through the lower outer openings (B).

NOTE: Wire extensions may need to be added to wiring.

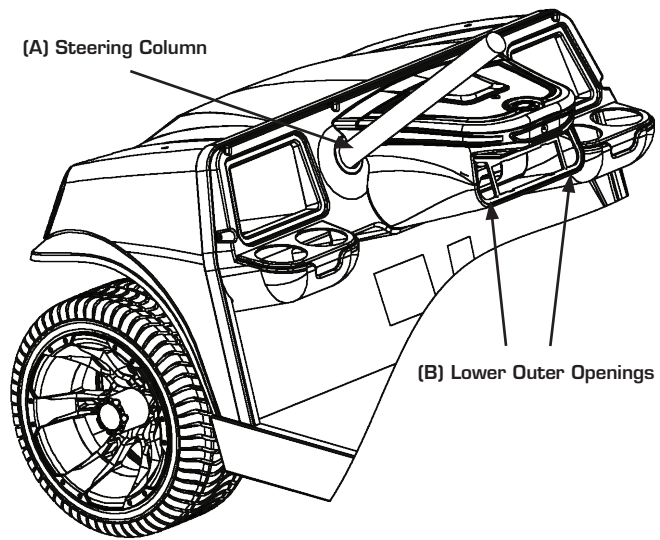

2:2 ATTACH SENTRY DASH

Once the dash is fully seated against aluminum car frame, use a 9/64" drill bit to drill pilot holes into the aluminum frame at the six screw locations (C) around the outer edges of the Sentry Dash. (Mounting holes located at the bottom of the dashboard (D) are optional).

Next, screw the dashboard in place with the six self-tapping pan-head screws provided.

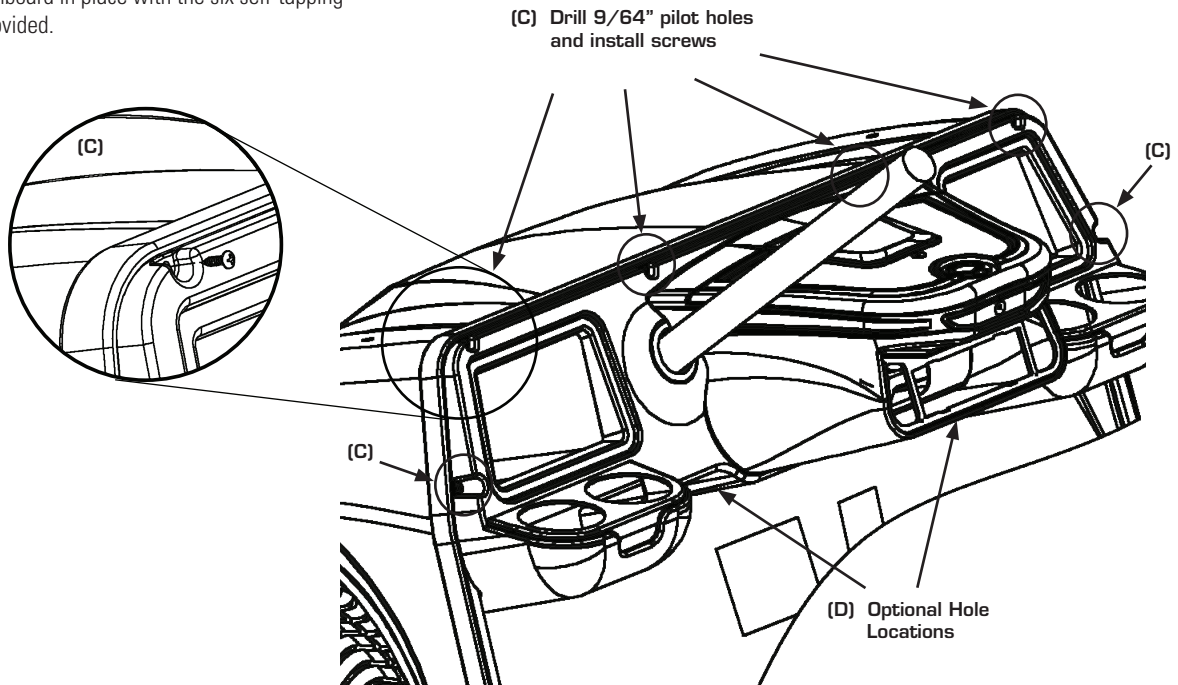

SECTION 3

TRIM KIT INSTALLATION

3:1 ATTACH CUP HOLDER INSERTS

Remove protective film from outer surface of Cup Holder inserts (E). Attach inserts to Sentry Dash with peel and stick tape provided.

NOTE: Items are left and right handed. Check for correct positioning before attaching with double-sided tape. The adhesive is automotive quality and may not be removeable without damage to the insert once applied.

Place and press Cup Holders (F) into insert openings.

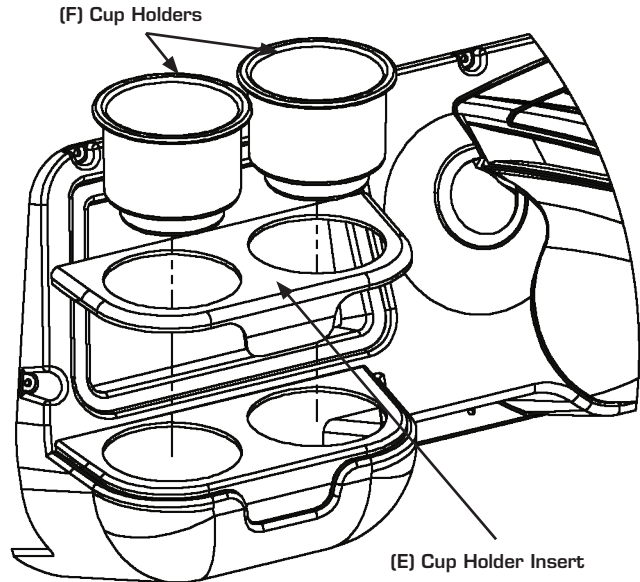

3:2 ATTACH STORAGE AND NOSE INSERTS

Remove protective film from outer surface of Storage insert (G) and Nose insert (H). Then attach inserts to Sentry Dash with peel and stick tape provided.

3:3 PREPARE FACEPLATE

Cut the necessary holes in the Faceplate insert (I) to install the electrical components that were taken out in section one. (Placement of these components varies by user). Install components and reconnect wiring.

3:4 INSTALL FACEPLATE

Insert the Faceplate Tray and Faceplate insert into the lower dash opening and attach with the 4 small flat head screws provided.

3:5 REATTACH STEERING WHEEL

Reattach the steering wheel to the steering column.

Installation is Complete.

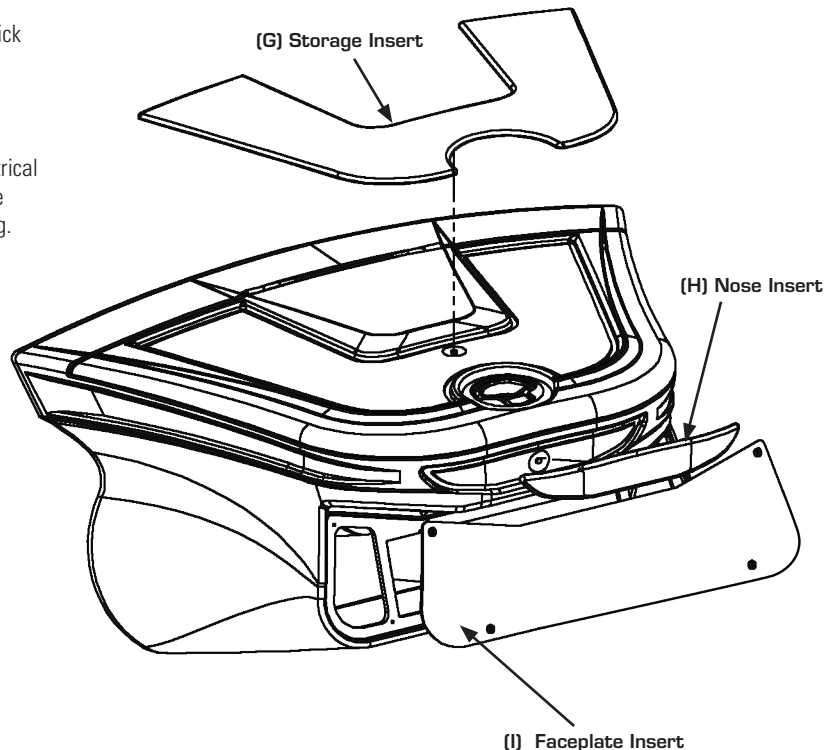



(This page left blank intentionally)